

The Propulsion of Sea Ships – in the Past, Present and Future –

(Speech by Bernd Röder on the occasion of the VHT General Meeting on 11.12.2008)

To prepare for today's topic, more specifically for the topic: ship propulsion of the future, I did what every reasonable person would have done in my situation if he should have a look into the future – I dug out our VHT crystal ball.



Every future and all statistics lie in the crystal ball

As you know, our crystal ball is a reliable and cost-efficient resource which we have been using for a long time with great success. Among other things, we've been using it to provide you with the repair costs or their duration or the probable claims experience of a policy, etc. or to create short-term damage statistics, as well.

So, I asked the crystal ball: What does ship propulsion of the future look like?

I must, however, admit that what I saw there was somewhat irritating, and it led me to only the one conclusion – namely, that we're taking a look into the very distant future at a time in which humanity has not only used up all of the oil reserves but also the entire wind. This time, we're not really going to get any further with the crystal ball.



Ship propulsion of the future or 'back to the roots'?

But, sometimes it helps to have a look into the past to be able to say something about the future. According to the principle, draw a line connecting the distant past to today and simply extend it into the future. So, let's fast-forward into the past.

In his speech from the first VHT-Training-Camp, my colleague, Michael Pfeiffer, reverted from the subject 'General Average' back to Hamurabi (thus, back to approx. 1700 B.C.). However, I'm not going to make it that easy for you.



Man paddled round for 35 thousand years

Even 40,000 years before Christ, man built boats and paddled through the waters with them. And, they paddled and paddled and paddled for 35,000 years until a major discovery revolutionised ship propulsion for the first time.

If you think I'm talking about the sail, you've guessed wrong. And, if you believe that I meant the diesel engine, then something's definitely wrong with your crystal ball. What I'm speaking about is the oar! Mankind paddled round for 35,000 years – just like the Indians – and then they began using oars –

similar to the tourists on the Alster lake. And then mankind oared round for several thousand years – namely, up to 3,000 B.C. (My colleague, Michael Pfeiffer, would say up to 1,300 before Hamurabi) until the sail was discovered, supposedly in Egypt. Now, finally, more than just the Nile and the coastal regions of the Red and Mediterranean Seas could be explored. The seafarers could then set off on voyages crossing the seas and circling the continents.

For a long time, the seaman couldn't give up using the oar and combined the oar with the sail.

Here, for the first time, we hit head-on the practice typical over a long period of time in seafaring: trust the tried and true and only replace it step-by-step with something new. This is a practice, which at its time certainly saved the lives of many seamen, and, in modern times, the abrogation



Roman warship with sail and oars – around 200 B.C.

thereof has cost the insurers a lot of money.

Then once again for a long time, very little happened, at least in the realm of ship propulsion. The ships got bigger and bigger, Hamurabi lived and died, and, finally, the oars were completely done away with. And, in this manner, mankind sailed almost 5,000 years – until the year 1770 A.D. when the Scotsman, James Watt, further developed the steam engine so that it, a short time thereafter, could be built into a ship.

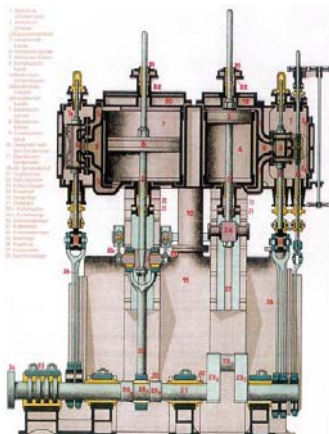

Cross-section and full-view of a 2-stage steam engine

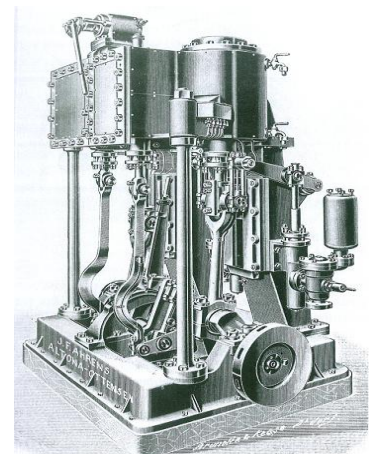

Unadvantageously, at this period in time, the propeller had not yet been invented. And, what was more convenient to make use of than the old-familiar paddle-wheel of the flour and lumber mills.

At this point, technically speaking, a radical change took place in regard to ship propulsion. Ships had always been powered directly so far, thus, by muscle or wind power, whereas starting at this point, they began to be powered indirectly. The paddle-wheel propelled the ship, and the steam engine drove the paddle-wheel and – if you'd like – the coal-fired boilers provided the steam for the steam engine.

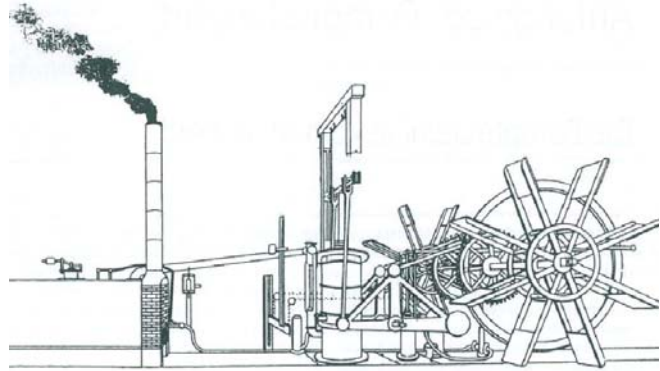

“Contemporary” depiction of propulsion (steam engine and paddle-wheel) of the steamboat "Claremont"

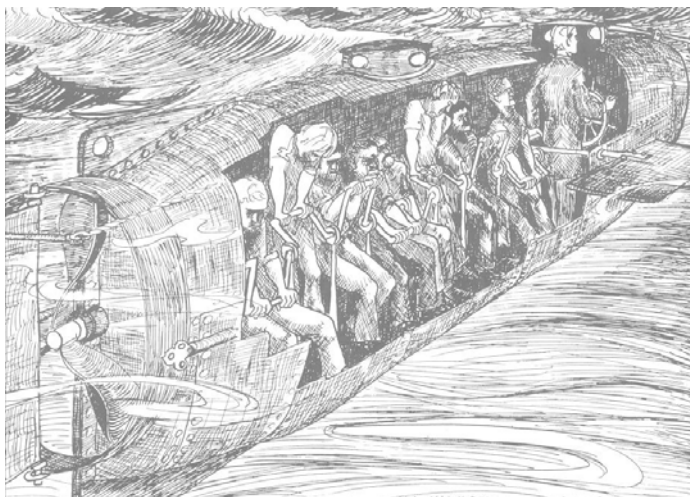

There were certainly attempts at interim solutions. This illustration is not a comic drawing but rather the then contemporary depiction of a submarine propelled by muscle power, which sank the "Housatonic" in 1864.

Submarine "H.L. Hunley" on 17.02.1864 while attacking the "Housatonic"

And **again**, one didn't throw the sail overboard and install a steam engine, rather one slowly felt his way forward – the ships had a sail and a steam engine and a paddle-wheel (later a propeller, as well).

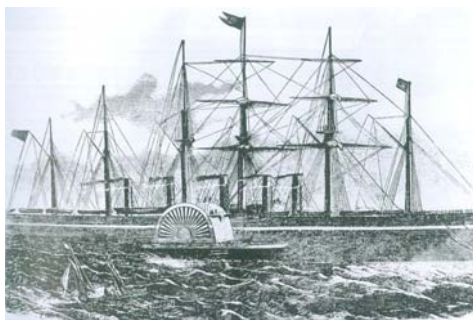

Steamship "Great Eastern" around 1860. The ship had 6 masts, 2 paddle-wheels and a four-bladed propeller

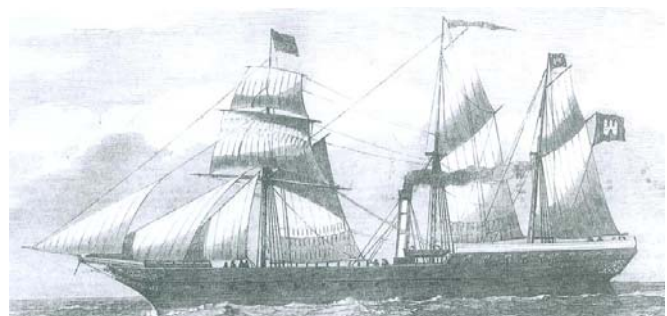

Steamship "Helena Sloman" around 1850. The ship had a full set of sails and a propeller

Then, 60 years later, in the year 1827, Joseph Ressel had the ship propeller patented. He was an Austrian and had the exciting title of a “Marineforstintendant” (something to the tune of Marine Forest Ranger Intendant) – well, why not, in the times of human resource managers, ego enhancement consultants and appraisers of intellectual capital, one must truly not wonder about a Marineforstintendant.

The iron propeller was a great improvement as compared with the wooden paddle-wheel with its many fragile pieces. And, even more importantly, the propeller was able to be adapted to all of the following types of propulsion and output standards of today. In my opinion, the propeller is not to be surpassed on simplicity and reliability when we’re speaking about propelling a ship through water.

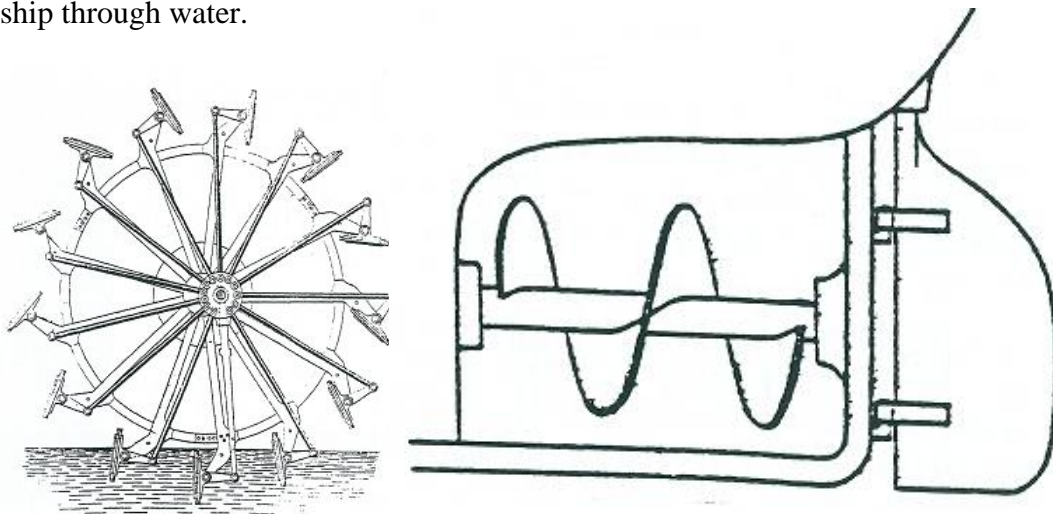

Depictions of a paddle-wheel and a “prototype” of a propeller



Meanwhile, propellers are built which can manage 120,000 hp and weigh over 130 tonnes having a diameter of just short of 10 metres. Here, the limit of possibility certainly seems to have been reached.

I don’t believe we must make our crystal ball predict that the propeller will power our ships in the distant future, as well. The question is merely – who or what will power the propeller?

5-bladed control pitch propeller for a container

Let's take just another look back into the century before the last, in which the steam engine set about replacing the sail. The demands made on output got bigger and bigger; the steam engines, as well.

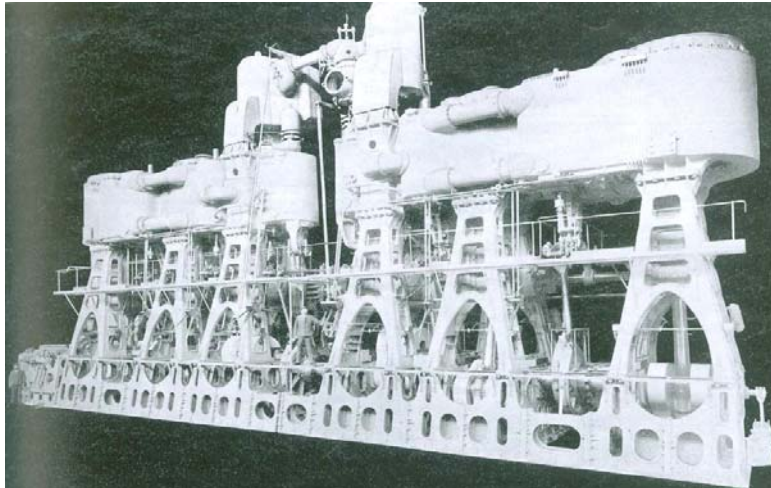

The performance limit of 20,000 hp per steam engine was quickly reached. So, several steam engines had to be built into a ship in addition to numerous boilers – sometimes 15 or more. Besides that, many hundreds of tonnes of coal had to be brought on board and stored.

One of the two steam engines of the steamship "Kronprinzessin Cecilie" (1907), 22.000 hpi

Around 1900, the first steam turbines were built into ships. While having a larger output, they required much less space than steam engines, but the old steam boilers remained on board, and they were still fired manually with coal.

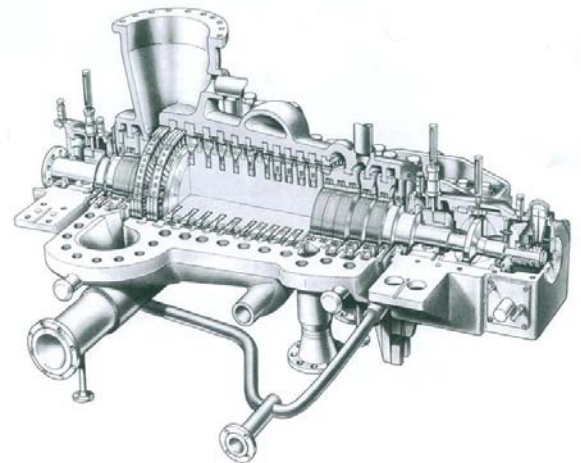

Cross-section of a high-pressure stage of a modern steam turbine

The amount of effort required to fire the boilers with coal is no longer imaginable today! One needed the coal heaver, who transported the coal from the storage room – from the coal bunker – up to just in front of the boiler; one needed the stoker, who shovelled the coal into the boilers and maintained the steam pressure; one needed the many helpers, who transported the ash from the boiler overboard. And, all of that for each individual boiler and for each of the three shifts.



View of the boiler room of a coal-fired steam boiler system

Around 1920, when the Hamburg-Süd steamship "Cap Polonio" was refitted from coal-firing to oil-firing, the boiler room personnel was able to be reduced by just 110 men.

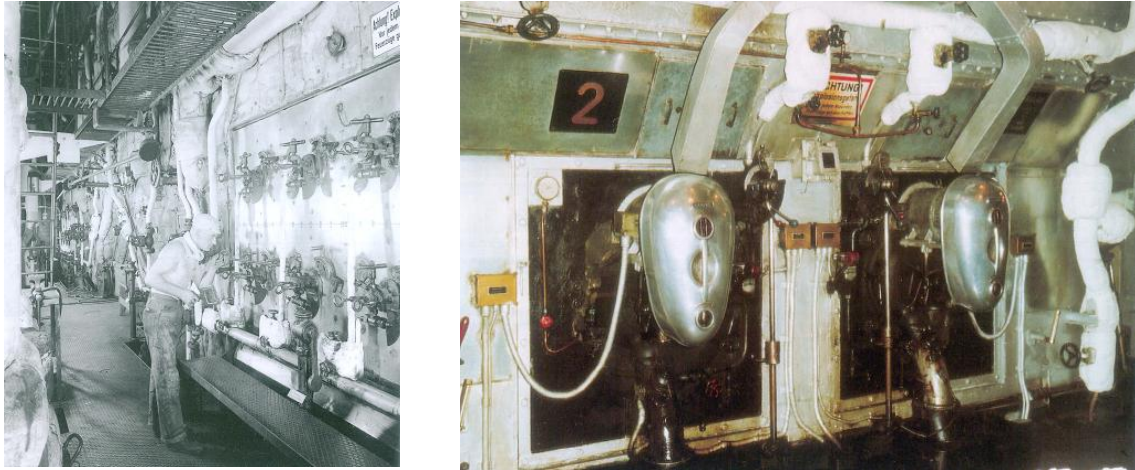

View of the furnace of two oil-fired steam boiler systems

Thus, in fact, one should think that he could lean back being satisfied. With the steam turbines, finally the industry had ship propulsion systems with - for ship standards – huge performance reserves available (today, stationary steam turbine systems are built with over 1.5 million horsepower per turbine). And, the oil-fired boilers were also quite comfortable.

But, don't forget about the enormous amount of fuel consumption! The efficiency of a steam turbine was, in comparison with a steam engine, from which only 10 to 20% of the energy used made it to the propeller, considerably better – but still left loads of room for improvement having only 25 or 30% efficiency.

And so, in regard to ship propulsion, the steam engine and the steam turbine only had a relatively short “cameo-appearance” in the greater scheme of things.

In the year 1876 – thus, 130 years ago – the combustion engine was invented by Nikolaus Otto. It had to, however, be driven with benzine, which at the time had to be purchased at the chemist's. Today, we buy our benzine at the petrol station, but the chemist's prices have remained.

The combustion engine was, thus, discovered, but it wasn't originally good for ship propulsion because it used much too much and much too expensive petrol.

Even 50 years before the invention of the Otto motor, the Frenchman, Carnot, described a thermo-dynamic cyclic process with theoretically the highest possible degree of efficiency. Don't worry, it won't start to get complicated or scientific – we'll remain on the subject: thermo-dynamics for beginners.

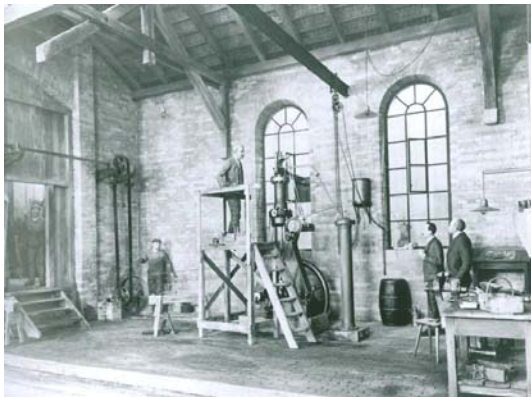

View of Robert Diesel's workshop with the first Diesel engine in the background (around 1895)

With the above in mind, Rudolf Diesel developed a combustion engine which operated according to the Carnot-principle and had the same patented in 1892. The 'diesel engine' reached a spectacularly high efficiency of 20, then 30, then 40 and finally 45 %.

Around 1910, one began to build diesel motors into ships as the main source of propulsion. You have to just imagine: the entire diesel engine took up approx. as much - no, as little - room as three boilers and, thereby, replaced a steam propulsion system, which perhaps was comprised of 2 turbines, 15 boilers and countless auxiliary units and, thereby, required 30 % less fuel.

From 1910 to today, the diesel engine has gone through an unparalleled technical development. Similar to the propeller, the diesel engine was able to be adapted to every demand on size and output performance.

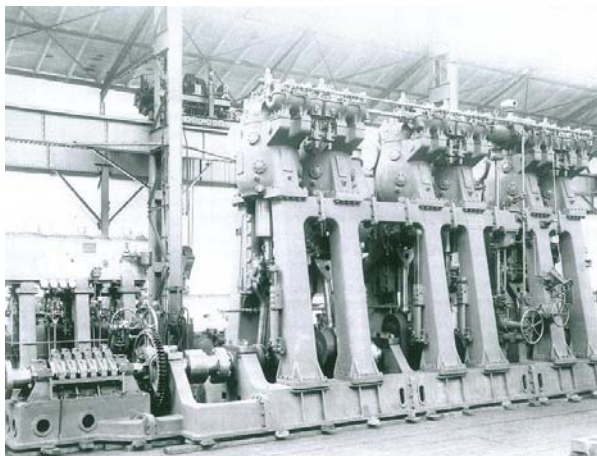

Right: Embedding of a crankshaft in a 12,000 hp 6-cylinder MAN two-stroke engine (around 1913)

Left: View of a large two-stroke diesel engine around 1912 (1,500 hp at 120 RPM)

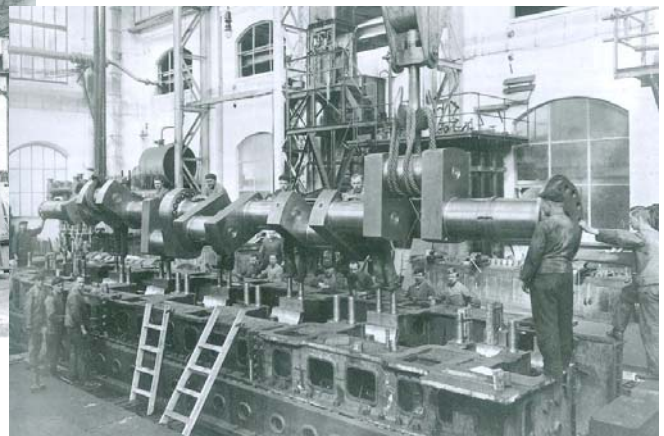

Ship diesel engines of today are available in every size and output class up to 135,000 hp. They are extremely reliable, and the so-called specific fuel consumption is unbeatably low with 119 grams per hp and hour (g/hph) – at its time, the steam engine consumed approx. 700 g/hph.

In addition, the 'combined heat and power' principle, which is talked about so often today, has been common practice in ships with diesel propulsion for ages. Heat is detracted from the diesel engine's exhaust gases, which, in spite of everything else, still contain about 50 % of the thermal energy used, by connected

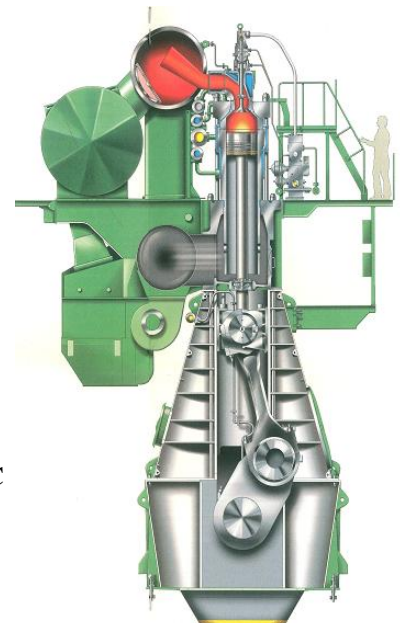

Cross-section of a MAN-B&W ship diesel engine 6S 70 ME-C (25.000 kW @ 91 RPM , weight - 550 t, height - 14 m)

turbo chargers and steam boilers so that the efficiency of the entire system rises to over 70 %.

As they say: 'what's better' is the enemy of 'what's good' – the diesel engine, thanks to its many advantages, has displaced every other type of propulsion in shipping. Today, approx. 90 % of all merchant vessels are propelled by diesel engines, world-wide.

However, the times of rapid technical developments in the ship diesel engine are gone – which, for one, lies in the fact that the highest possible degree of efficiency has almost been reached, and, for another, that the now possible output of 150,000 hp can no longer be surmounted by one single propeller. There is no longer any reason to boost the output of any one single ship diesel engine. In case it's necessary – now, two engines would have to power two propellers - and then there would be 300,000 hp of installed propulsion output. The size of merchant vessels which would require such an amount of output are not imaginable today, and such vessels won't be playing a roll in shipping in the intermediate-term.

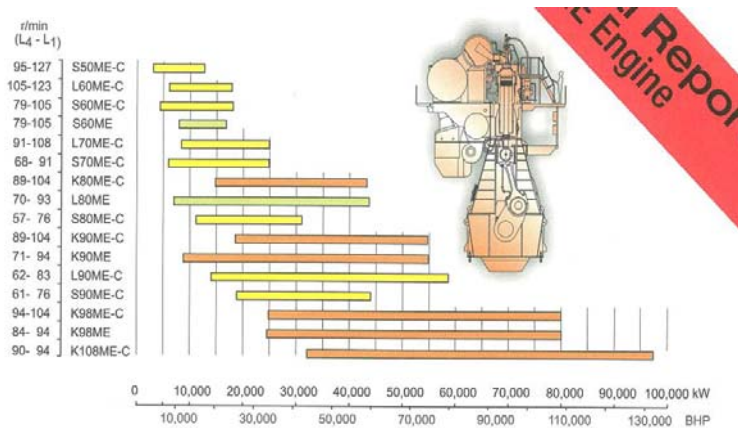

Here, you can see the current MAN-B&W model range of two stroke diesel engines for ships, beginning at the upper left with 4,000 hp and ending at the bottom right with 135,000 hp.

As I've already mentioned, the diesel engine has almost displaced every other type of propulsion and is absolutely market dominating.

Overview of the current B&W-MAN model range of two stroke diesel engines for ships

It displaced the steam turbine, which today only plays a secondary role in regard to ship propulsion.

It displaced the nuclear powered merchant vessels which were built in the 60's of the previous century – namely, the Savannah (USA), the Otto Hahn (Germany) and the Mutsu (Japan).

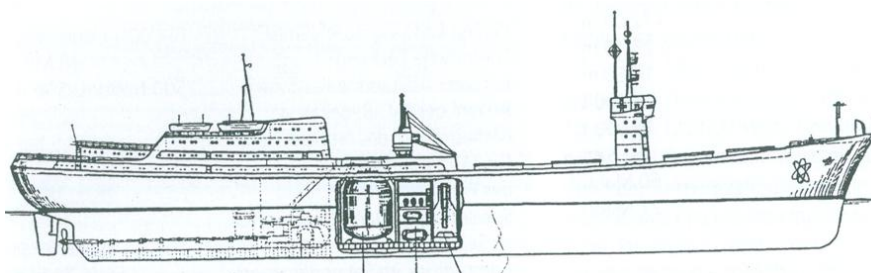

NS "Otto Hahn" - 1965

All three ships were powered by propellers, which, in turn, were driven by steam turbines typical of merchant ships – only that the steam was not produced in oil-fired boilers but rather in a so called pressurised-water reactor.



View of the pressurised-water reactor of the NS "Otto Hahn"

The diesel engine also displaced ships with gas turbine propulsion. These ships had airplane jet engines, which functioned as so-called gas generators which, in turn, powered turbines. The latter rotated similar to a steam turbine and powered our old-familiar propeller.

The ships were extremely expensive and uneconomical, and at their time they were only able to touch at very few ports worldwide owing to a lacking acceptance in the population. They also required a large number of well-trained crew members. The "Otto Hahn" had e.g. a regular crew of nearly 60 men plus 35 scientists on board. All three ships were either taken out of service relatively quickly or converted to conventional steam production.

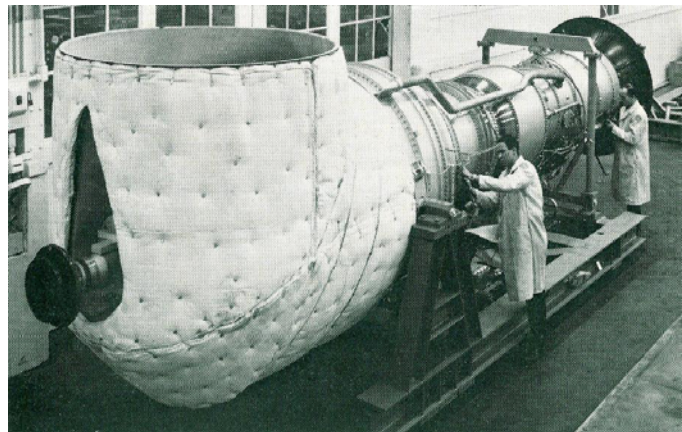

Pratt & Whitney gas turbine FT 4 A12 (30.000 Ps) of the GTS "Asia Liner"

Even this type of propulsion was extremely uneconomical in that it, for one, required the same top-quality, expensive fuel as that of an airplane jet engine and on top of that, it had an efficiency of only 21 % which was – at least in comparison to that of a diesel engine – awfully low. Every ship with gas turbine propulsion known to me was converted to diesel engine propulsion after a few years.

In the table below, you can compare the degrees of efficiency and specific fuel consumption of the various types of propulsion. The specific fuel consumption is, by the way, the amount of fuel that the system must be given in order to produce 1 hp for one hour (g/hph). You see that we've worked down from 700 g/hph to 120 g/hph today.

Comparison of the thermal degrees of efficiency and specific fuel consumption		
	efficiency	specific fuel consumption
sail	./.	0
steam engine	10 – 15 %	700 g/hph
gas turbine	21 %	320 g/hph
steam turbine	30 %	220 g/hph
diesel engine	45 %	120 g/hph
hydrogen	30 %	./.

So much for ship propulsion in the past and present. And now, we'll ask ourselves whether our "look" into the history of ship propulsion has brought us any further than our "look" into the crystal ball.

I sincerely believe we know that ship propulsion must be reliable and, above all, economical. Diesel propulsion satisfies both requirements thoroughly and without any competition – at least as long as heavy fuel or diesel oil or, as the case may be, liquid gas (LNG) is readily available and affordable.

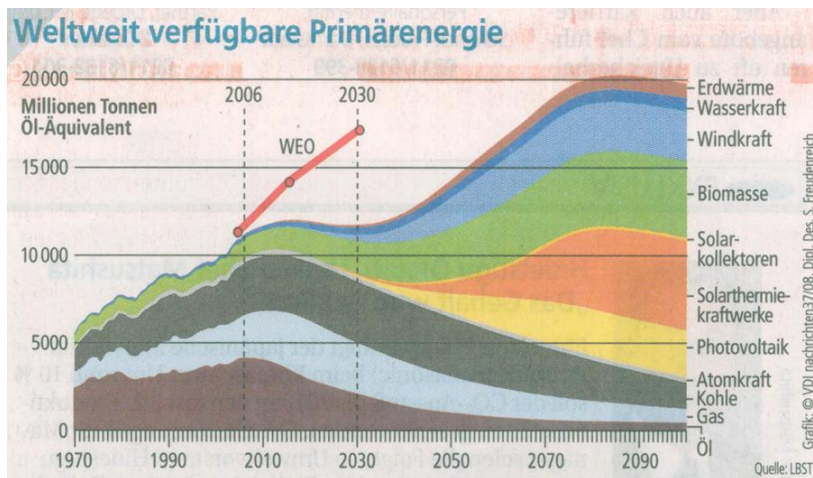

The graph on the left shows that we have nearly reached the pinnacle of the available primary sources of energy / crude oil (Öl) and natural gas (Gas) – we find ourselves shortly before that point and will have reached it by 2010 – at least according to the graph (we're talking about the brown and blue areas at the bottom). At that point, oil and gas will run short with

rising energy consumption worldwide in favour of biomass (coloured green), photovoltaics (yellow), wind energy (blue) and solar heat (orange).

Beginning in 2070, oil appears – in comparison to today – to play a rather inferior role. In other words, there is little to be said against the diesel engine's maintaining its dominating role in the market at least until 2030. A short-term shortage of fuel – as was the case a few months ago, when the oil price rose to 160 USD/barrel and, consequently, the heavy fuel price rose to over 500 USD/tonne – will not change anything about this development.

However, it does make sense to think about the years beyond 2030 – at the end of the day, it is only one "ship-life" long until then, and none of us must grow to be as old as the Queen Mum to experience it.

It doesn't make any sense to speculate about photon, electron or 'caterpillar drive' ("The Hunt for Red October" sends its regards). All of those things may not, in deed, be impossible – but they are not on the horizon and, thus, speculative.

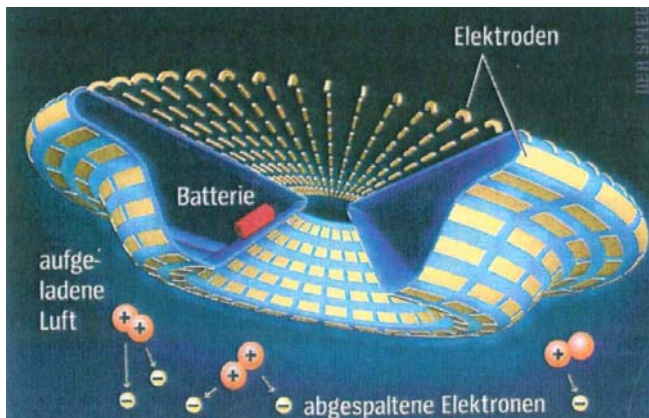

'UFO Number 1' with electron propulsion – speculative!

And, the SkySail or the Flettner-Rotor don't really help us out of the predicament, either. Our ships need propulsion independent of the weather and with enormously large output. "Auxiliary propulsion units" cannot manage this by far.



Left: SkySail – only suitable for „auxiliary propulsion“!

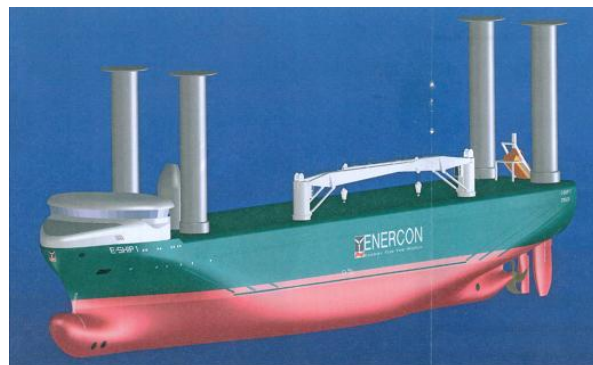

Right: Flettner-Rotors – only suitable for „auxiliary propulsion“!

What is in sight and even what is already being applied – at least for special ships such as submarines – is hydrogen propulsion. The term "hydrogen propulsion" is just as misleading as "nuclear propulsion". A ship with hydrogen propulsion is still powered by our „not to be killed“ propeller and the latter by an electric motor. Both components are old friends – the propeller, anyhow, and the electric motor has already been implemented in the so-called diesel-electric propulsion for many years. Thereby, a diesel engine powers an electric generator of which energy goes to an electric motor, which, in turn, powers the propeller. The last step of this development is the so-called 'Azipod', which contains the electric motor directly in the pod (gondola) behind the propeller.



Electric 'Azipod' propulsion

Above: View of the 'gondolas' with drag-propeller

Right: Schematic diagram with view of the mounted electric engine in the 'gondola'



In regard to hydrogen propulsion, we can manage without a diesel engine and a generator as we produce the energy for the electric engine e.g. from the fusion of hydrogen and oxygen, whereby water and heat are generated – so-to-speak as by-products – in addition to the energy, itself. In Hamburg, some buses are already powered by hydrogen cells, and Thyssen Krupp has been successfully building submarines using this technology.

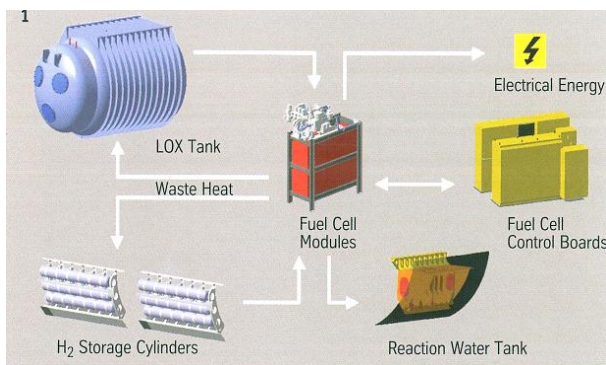

Left: Functional principle of a hydrogen cell

Right: Technical layout of a hydrogen cell for submarines

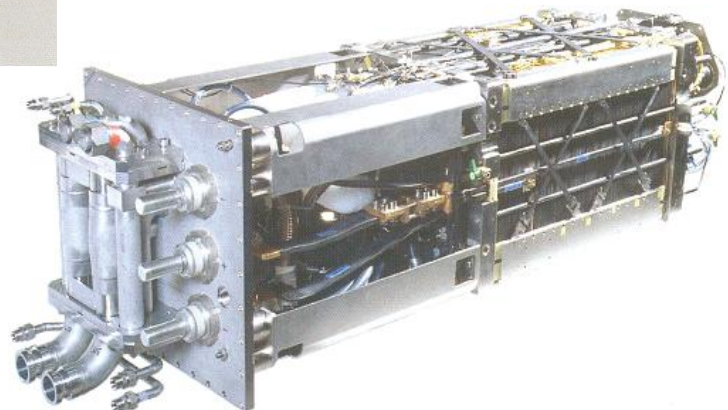

If you're beginning to think that we've found the solution of striking simplicity with hydrogen cells, I have to disappoint you. In this world, there isn't any "free hydrogen" flying round. It reacted a long time ago with oxygen and is now floating round as water.

But now, the good news: one can split water by means of electric or solar energy into its two components once again – hydrogen and oxygen. This is how e.g. our buses in Hamburg have their hydrogen produced.

You may be familiar with this topic from physics lessons – topic: electrolysis: take one glass of water, add two electrodes, hook it up to a direct current, and already, you've got hydrogen gas coming out of the glass, which, when it's hardly even reached the top of the glass, reacts again with the oxygen in the air producing a loud bang.

It wouldn't, however, be very reasonable to take the energy out of the receptacle on the wall – first of all, because we need a direct current and secondly, because we've just seen in the diagram that the primary energies / oil, gas and coal won't be so readily available in a few years whereas photovoltaics, solar heat, biomass and wind power will be richly available. So, what lies closer to the means of producing energy and, thus, hydrogen than photovoltaics, biomass or wind power?

Every day, the sun radiates 5,000 times more energy at the earth than mankind needs. It would really be pathetic for us not to be able to tap into 1/5000 of it. e.g. in which we produce solar heat in the deserts and, thereby, in turn, hydrogen, which we convert into liquid on location and finally, transport with hydrogen-powered ships to the consumer to power Hamburg buses and cars and to heat flats – what a wonderful world without CO₂ and respirable dust.

Liquid hydrogen has a high energy density and is easy to transport, an important pre-requisite for every energy source, which should power a driving, flying or floating object. So, whenever the diesel engine is displaced in a day not too far in the distant future as the type of propulsion for the propeller, then, in my opinion, it will be by means of an electric motor powered by hydrogen energy.

.oOo.